

F28BK-0*C-111
WITH INNER & OUTER LIGHT PIPES

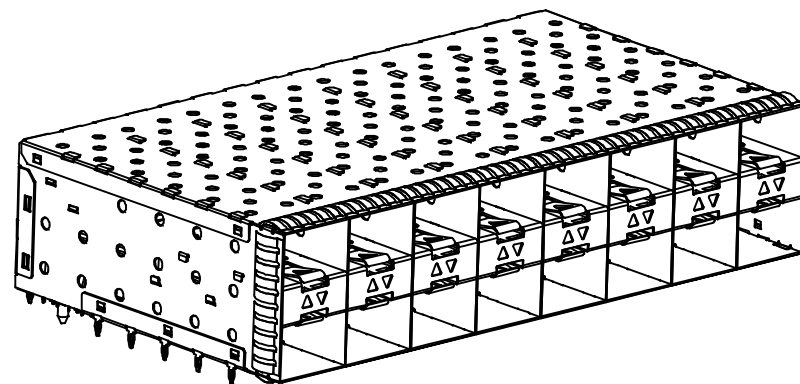

F28BK-0*C-131
WITH INNER LIGHT PIPES

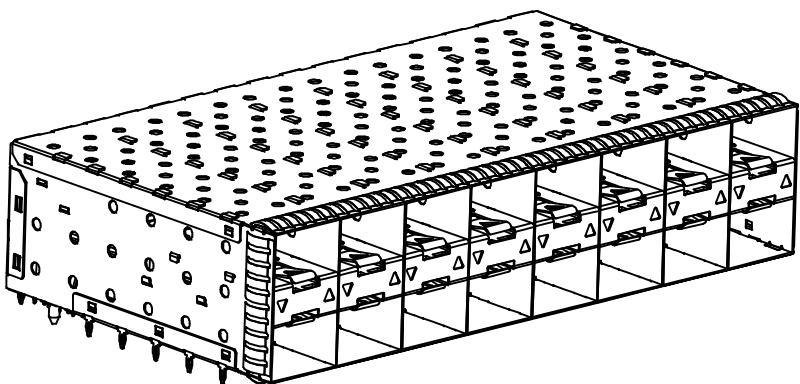

F28BK-0*C-121
WITH OUTER LIGHT PIPES

A

A

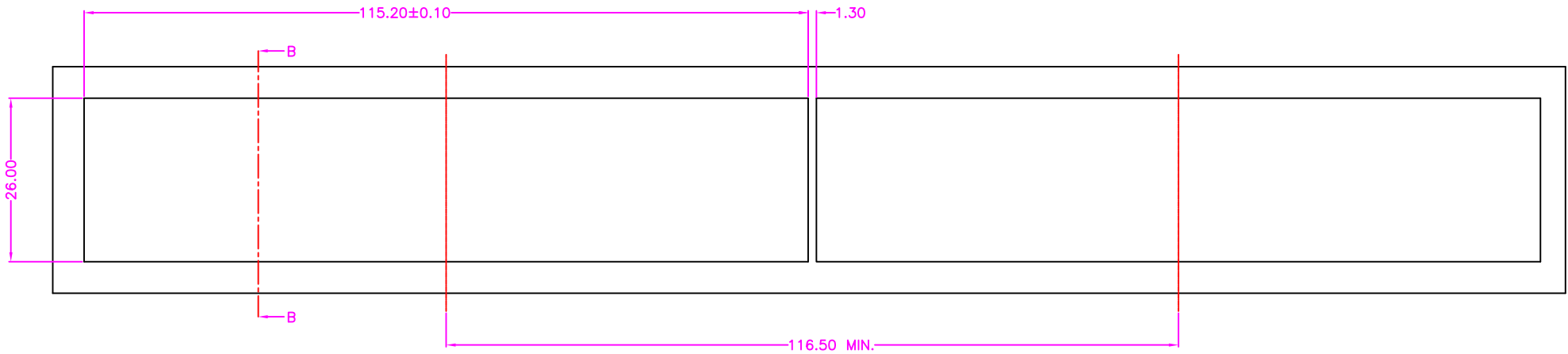

B

B

RECOMMENDED PANEL CUTOUT AND PC BOARD
 PANEL POSITION AND THICKNESS 0.8-2.6

MATERIALS

SFP CONNECTOR
 HOUSING: HI-TEMP. PLASTIC (UL 94V-0), BLACK
 TERMINAL: COPPER ALLOY, GOLD PLATED ON CONTACT AREA
 TIN PLATING ON SOLDER TAIL

SFP CAGE
 TOP SHIELD: COPPER ALLOY, NICKEL PLATING
 MIDDLE SHIELD: COPPER ALLOY, NICKEL PLATING
 BOTTOM SHIELD: COPPER ALLOY, NICKEL PLATING
 BACK SHIELD: COPPER ALLOY, NICKEL PLATING
 BRACKET: COPPER ALLOY, NICKEL PLATING
 EMI SPRING: STAINLESS STEEL

LIGHT PIPE: PC

C

C

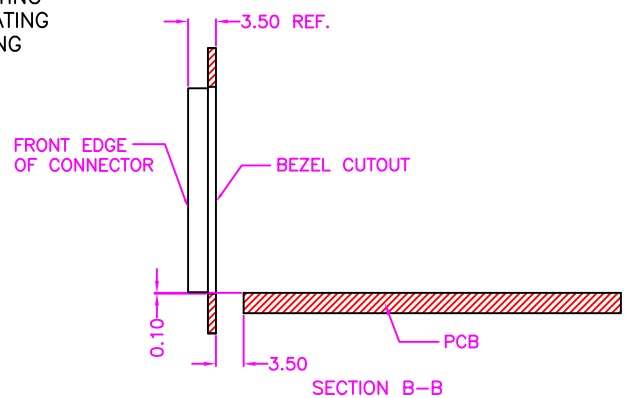

SECTION B-B
 BEZEL OPENING ABOVE
 TOP OF PC BOARD

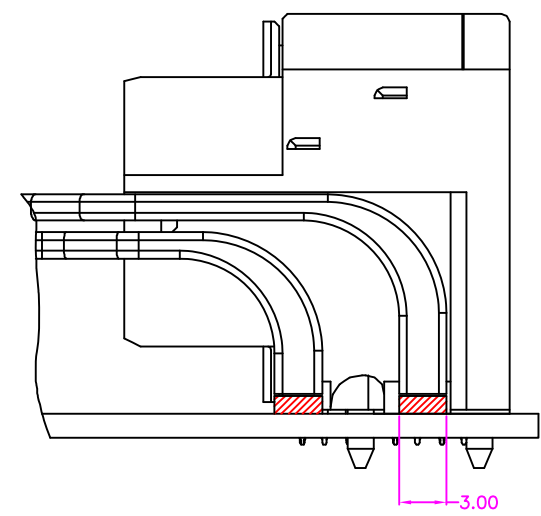

LED CLEARANCE REQUIREMENTS
 SCALE 2:1

D

D

ZICONN
 ELECTRONIC CO., LTD.
 WWW.ZICONN.COM 886-3-4687695

TOLERANCES	
X.±0.40	.XX±0.20
.X±0.30	.XXX±0.10

REV.	A

DRAWN BY	Zhong 2020/2/10
APPROVED BY	Lion 2020/2/10

TITLE	STACKED SFP+ 2x8 CAGE, R/A, METAL SHIELD PRESS FIT TYPE WITH CONNECTOR & LIGHT PIPE & EMI SPRING
DRAW NO.	F28BK-001

UNIT	MM	Sheet	3/4
------	----	-------	-----

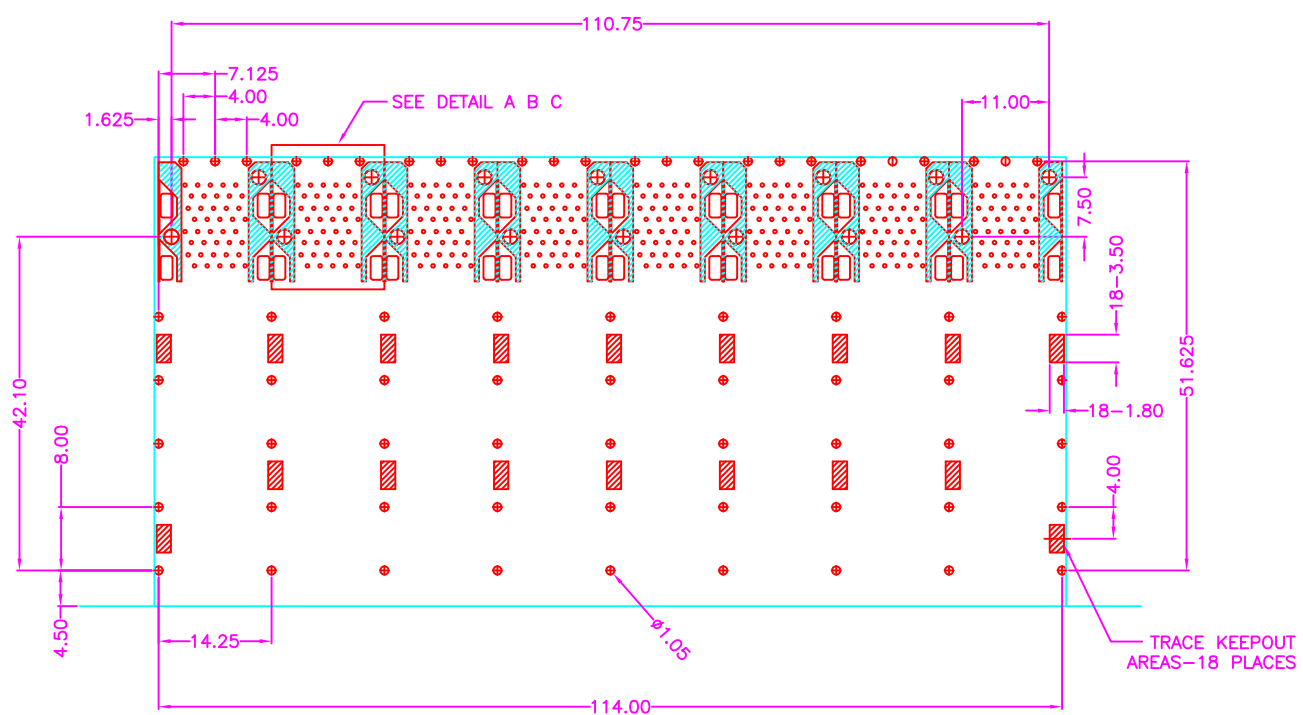

P.C.B LAYOUT
TOP VIEW ±0.05

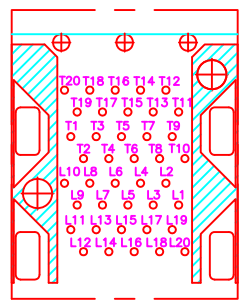

DETAIL A
SCALE 2:1

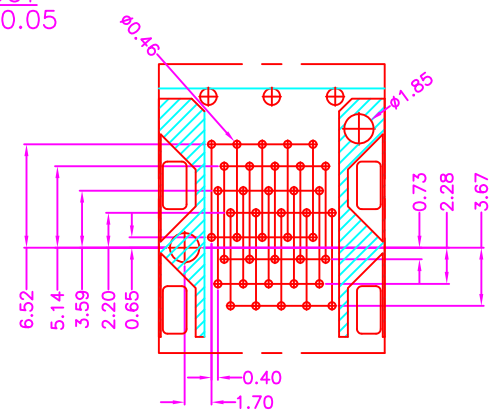

DETAIL B
SCALE 2:1

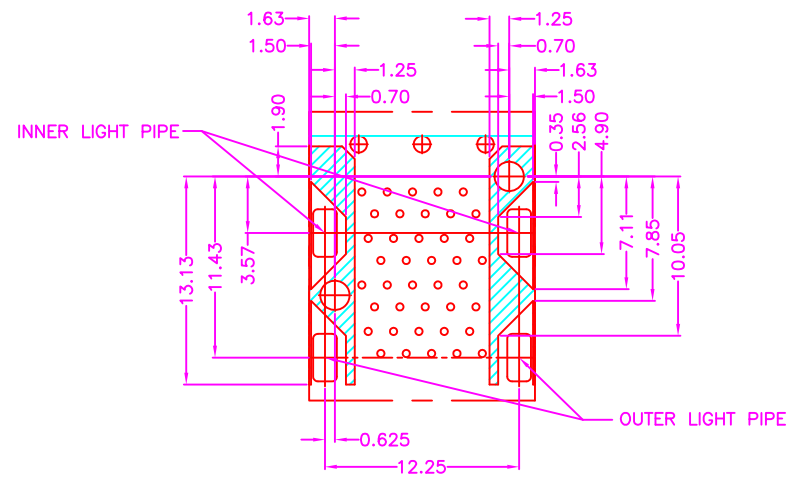

DETAIL C
SCALE 2:1

ZICONN
ELECTRONIC CO., LTD.
WWW.ZICONN.COM 886-3-4687695

TOLERANCES	
X.±0.40	.XX±0.20
.X±0.30	.XXX±0.10

REV.	A

DRAWN BY	Zhong 2020/2/10
APPROVED BY	Lion 2020/2/10

TITLE	
DRAW NO.	

STACKED SFP+ 2x8 CAGE, R/A, METAL SHIELD PRESS FIT TYPE WITH CONNECTOR & LIGHT PIPE & EMI SPRING				
F28BK-001	UNIT	MM	Sheet	4/4